

Sales Code: CSB120BN

Description: Victrion Superbe Rigid Riser Kit

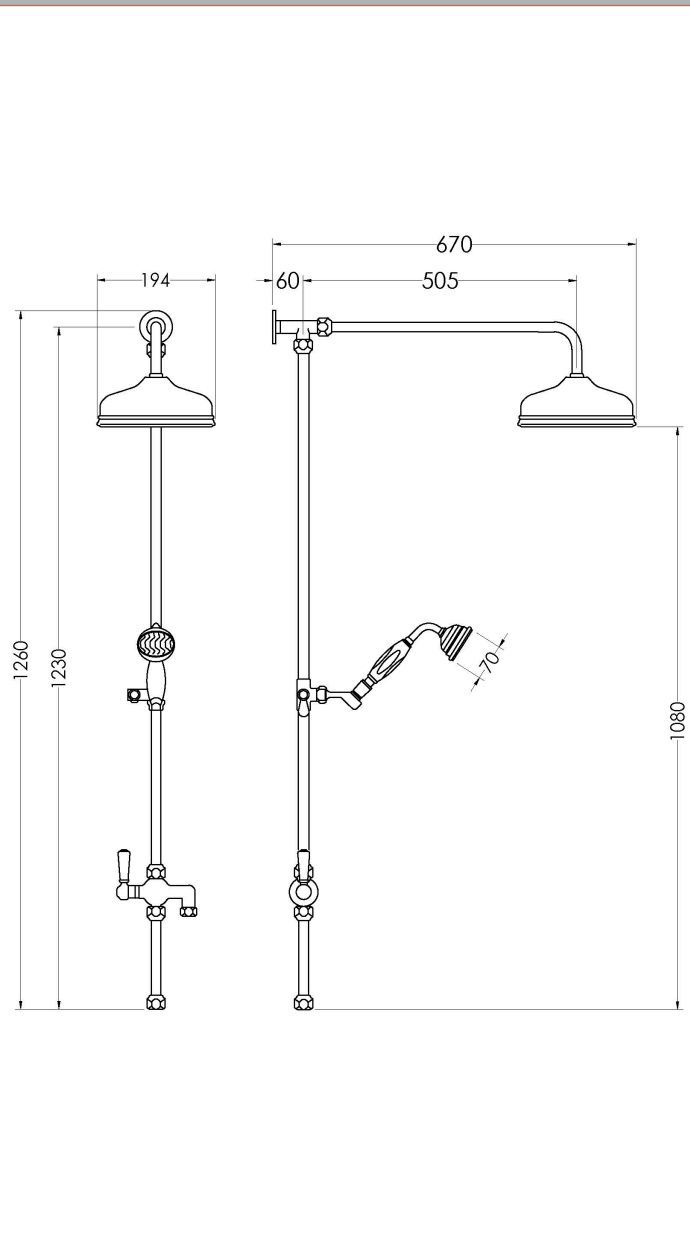

Product Dimensions

Length (mm):	
Width (mm):	
Height (mm):	
Depth (mm):	
Nett Weight (kg):	4.7

Packaging Dimensions

Length (mm):	1100
Width (mm):	240
Height (mm):	110
Gross Weight (kg):	5.2

Packaging Data

Box Colour:	
Box Qty:	
Label Size:	x
Label Colour:	
Label Qty:	

Outer Box Dimensions (If Applicable)

Length (mm):	
Width (mm):	
Height (mm):	
Depth (mm):	
Gross Weight (kg):	
Barcode:	5056462639987

Product Details

Country of Origin:	United Kingdom
Fitting Instruction:	No
Product Material:	
Mount Type:	
Outlet Elbow Supplied:	
Easy Clean:	
Head Included:	
Handset Included:	
Body Jets Included:	
No of Body Jets:	
Operating Pressure (bar):	
Valve/Cartridge Type:	
Flow Rates (L/min):	0.1 bar: 0.5 bar: 1 bar: 2 bar: 3 bar:
TMV2 Approved:	Approval No:
TMV3 Approved:	Approval No:
WRAS Approved:	Approval No:
Head Function:	
Handset Function:	
Body Jet Info:	
Pipe Size:	
Pipe Centres:	
Colour/Finish:	
Hose Included:	
No. of Outlets:	