

Sales Code: FLT893

Description: 600 W/H 2-Drawer Unit

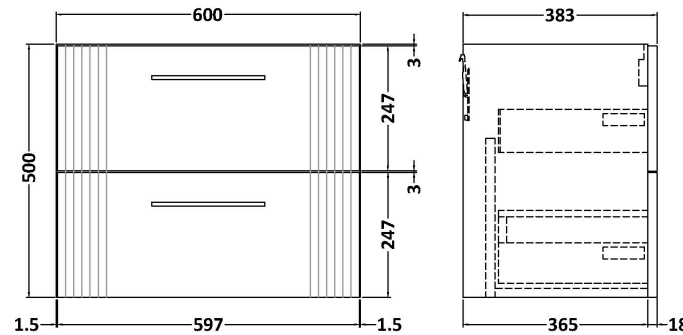
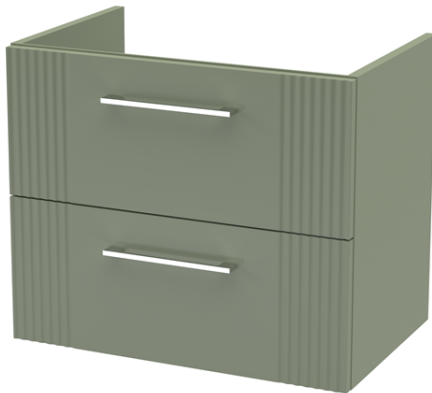

### Product Dimensions

|                   |      |
|-------------------|------|
| Height (mm):      | 500  |
| Width (mm):       | 600  |
| Depth (mm):       | 383  |
| Nett Weight (kg): | 22.5 |

### Packaging Dimensions

|                    |     |
|--------------------|-----|
| Height (mm):       | 520 |
| Width (mm):        | 620 |
| Depth (mm):        | 405 |
| Gross Weight (kg): | 23  |

### Packaging Data

|               |                               |
|---------------|-------------------------------|
| Box Colour:   | Brown Cardboard Box - Printed |
| Box Qty:      | 0                             |
| Label Size:   | 0 x 0                         |
| Label Colour: | Not Applicable                |
| Label Qty:    | 0                             |

### Outer Box Dimensions (If Applicable)

|                    |               |
|--------------------|---------------|
| Height (mm):       |               |
| Width (mm):        |               |
| Depth (mm):        |               |
| Gross Weight (kg): |               |
| Barcode:           | 5056462655512 |

### Product Details

|                          |                           |
|--------------------------|---------------------------|
| Country of Origin:       | China                     |
| Fitting Instruction:     | No                        |
| CE & UKCA:               |                           |
| FSC Certified Materials: | Yes                       |
| Colour:                  | Satin Green               |
| Construction Method:     | Cam & Wood Dowel          |
| Construction Type:       | Rigid                     |
| Cabinet Finish:          | MFC Painted Gloss         |
| Fascia Finish:           | Mdf Painted Gloss         |
| Cabinet Thickness (mm):  | 16                        |
| Fascia Thickness (mm):   | 18                        |
| Drawer Included:         | Yes                       |
| Drawer Type:             | 80mm High Metal Softclose |
| No of Shelves:           | 0                         |
| Hinge Type:              | Not Applicable            |
| Hinge Included:          | No                        |
| Adjustable Legs:         | No, Not Required          |
| Fixings Included:        | Yes                       |
| Handle Style:            | Modern                    |
| Waste Shroud:            | Yes                       |
| Handle Included:         | Yes, Supplied             |
| Handle Type:             | Bar                       |