

Sales Code: NPF2223

Description: 600 W/H 2-Door Unit (385 Deep)

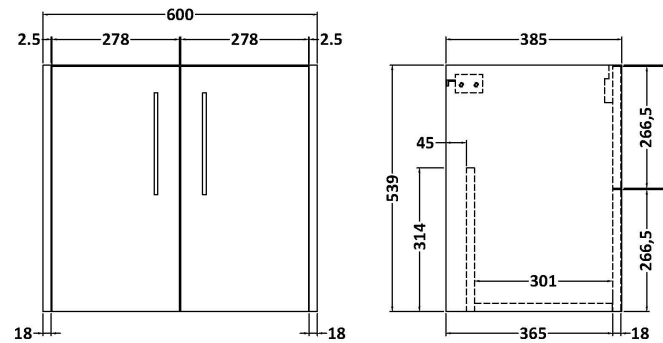

Product Dimensions

Height (mm):	539
Width (mm):	600
Depth (mm):	385
Nett Weight (kg):	14.2

Packaging Dimensions

Height (mm):	560
Width (mm):	620
Depth (mm):	405
Gross Weight (kg):	14.7

Packaging Data

Box Colour:	Brown Cardboard Box
Box Qty:	1
Label Size:	50 x 100
Label Colour:	White Label
Label Qty:	2

Outer Box Dimensions (If Applicable)

Height (mm):	
Width (mm):	
Depth (mm):	
Gross Weight (kg):	
Barcode:	5056462657097

Product Details

Country of Origin:	United Kingdom
Fitting Instruction:	No
CE & UKCA:	
FSC Certified Materials:	Yes
Colour:	Graphite Grey Woodgrain
Construction Method:	Cam & Wood Dowel
Construction Type:	Rigid
Cabinet Finish:	MFC Textured Woodgrain
Fascia Finish:	MFC Textured Woodgrain
Cabinet Thickness (mm):	18
Fascia Thickness (mm):	18
Drawer Included:	No
Drawer Type:	Not Applicable
No of Shelves:	0
Hinge Type:	95 Degree Clip-On Soft Close
Hinge Included:	Yes, Supplied
Adjustable Legs:	No, Not Required
Fixings Included:	Yes
Handle Style:	Modern
Waste Shroud:	No
Handle Included:	Yes, Supplied
Handle Type:	D-Shape