

Sales Code: NPF2226

Description: 800 W/H 2-Drawer Unit (385 Deep)

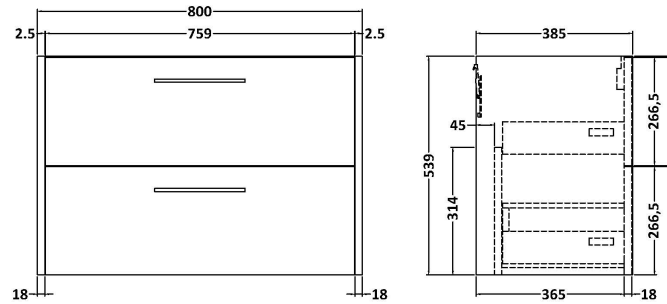

### Product Dimensions

Height (mm):	539
Width (mm):	800
Depth (mm):	385
Nett Weight (kg):	24.5

### Packaging Dimensions

Height (mm):	560
Width (mm):	820
Depth (mm):	405
Gross Weight (kg):	25

### Packaging Data

Box Colour:	Brown Cardboard Box
Box Qty:	1
Label Size:	50 x 100
Label Colour:	White Label
Label Qty:	2

### Outer Box Dimensions (If Applicable)

Height (mm):	
Width (mm):	
Depth (mm):	
Gross Weight (kg):	
Barcode:	5056462657295

### Product Details

Country of Origin:	United Kingdom
Fitting Instruction:	No
CE & UKCA:	
FSC Certified Materials:	Yes
Colour:	Graphite Grey Woodgrain
Construction Method:	Cam & Wood Dowel
Construction Type:	Rigid
Cabinet Finish:	MFC Textured Woodgrain
Fascia Finish:	MFC Textured Woodgrain
Cabinet Thickness (mm):	18
Fascia Thickness (mm):	18
Drawer Included:	Yes
Drawer Type:	80mm High Metal S/C Inc Galler
No of Shelves:	0
Hinge Type:	Not Applicable
Hinge Included:	No
Adjustable Legs:	No, Not Required
Fixings Included:	Yes
Handle Style:	Modern
Waste Shroud:	Yes
Handle Included:	Yes, Supplied
Handle Type:	D-Shape