

Sales Code: SML1433

Description: 600 F/S 2-Drawer Unit

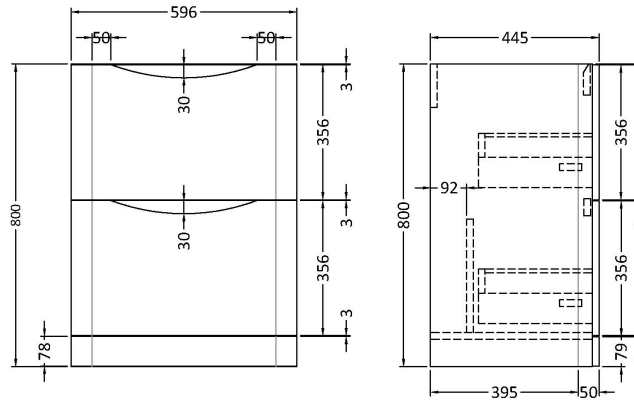

Product Dimensions

Height (mm):	800
Width (mm):	596
Depth (mm):	445
Nett Weight (kg):	33.5

Packaging Dimensions

Height (mm):	840
Width (mm):	640
Depth (mm):	480
Gross Weight (kg):	34

Packaging Data

Box Colour:	Brown Cardboard Box - Printed
Box Qty:	1
Label Size:	100 x 50
Label Colour:	White Label
Label Qty:	2

Outer Box Dimensions (If Applicable)

Height (mm):	
Width (mm):	
Depth (mm):	
Gross Weight (kg):	
Barcode:	5056462694450

Product Details

Country of Origin:	China
Fitting Instruction:	No
CE & UKCA:	N/A
FSC Certified Materials:	Yes
Colour:	Satin Soft Black
Construction Method:	Cam & Wood Dowel
Construction Type:	Rigid
Cabinet Finish:	MFC Painted Matt
Fascia Finish:	Mdf Painted Matt
Cabinet Thickness (mm):	18
Fascia Thickness (mm):	18
Drawer Included:	Yes
Drawer Type:	80mm High Metal S/C Inc Galler
No of Shelves:	Not Applicable
Hinge Type:	Not Applicable
Hinge Included:	Not Applicable
Adjustable Legs:	No
Fixings Included:	Yes
Handle Style:	Contemporary
Waste Shroud:	Yes
Handle Included:	Yes
Handle Type:	Inset