

Sales Code: WAS080G

Description: Exposed Bath Trap With Adapter (40/42mm)

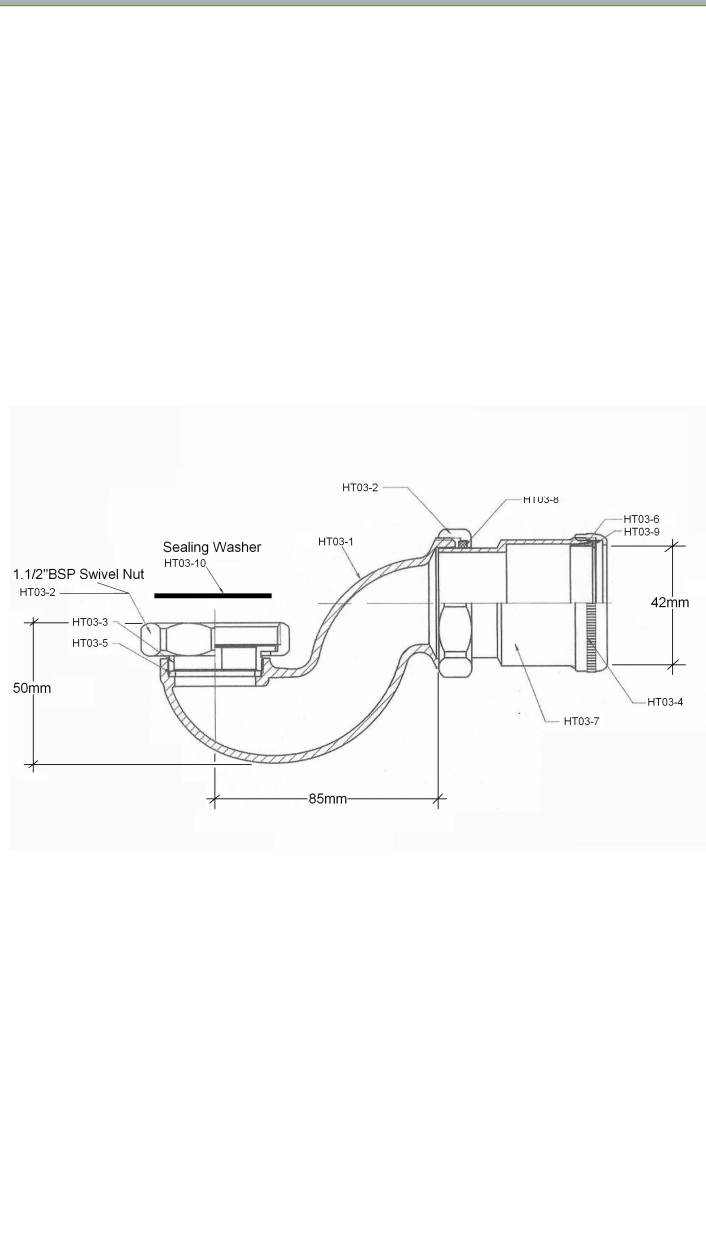

Product Dimensions

Length (mm):	
Width (mm):	
Height (mm):	
Depth (mm):	
Nett Weight (kg):	1.6

Packaging Dimensions

Height (mm):	660
Width (mm):	230
Depth (mm):	65
Gross Weight (kg):	1.6

Packaging Data

Box Colour:	
Box Qty:	
Label Size:	x
Label Colour:	
Label Qty:	

Outer Box Dimensions (If Applicable)

Height (mm):	
Width (mm):	
Length (mm):	
Depth (mm):	
Gross Weight (kg):	
Barcode:	5056462662176

Product Details

Country of Origin:	United Kingdom
Fitting Instruction:	No
CE & UKCA:	
Product Material:	
Heating Element Wattage:	
Colour/Finish:	
Product Diameter:	
Connection Size:	